

RENOVATION WORKS FOR THE OIC LTD.  
AT 103 a to 112 a sec 27 noida up

**Proposed Repair, Maintenance and  
Rain Water Harvesting Works**

**FOR  
RESIDENTIAL FLATS AT - 103 A TO 112 A, SEC-27, NOIDA UP.**

**THE ORIENTAL INSURANCE CO. LTD.  
ASAF ALI ROAD, NEW DELHI**

**TENDER DOCUMENT  
PART -I**

ARCHITECTS:

**A.V. ARCHITECTS**

**Architects and Interior Designers**

**Address :Office and Studio: JG-III, 65-A, Ground Floor,  
Vikaspuri, New Delhi-110018,  
TeleFAX: 28547855, 9810035321**

Dated: ...../...../2012

Total No. of Pages	Technical Bid =
	Financial Bid =

**APPENDIX SHOWING IMPORTANT SCHEDULES**

1. COMMENCEMENT OF WORK : Within ten days of the issue of letter of intent/order.
2. PERIOD OF COMPLETION : Ninety (90) Days.
3. LIQUIDATED DAMAGES : Rs. 2000/- per day subject to the max of 10% of the Accepted Contract sum.
4. PERIOD AND VALUE OF RUNNING/ON ACCOUNT BILL : Fifteen days ,minimum 3 lac.
6. TOTAL RETENTION AMOUNT : 10% of cost of works executed + EMD.
7. REFUND OF RETENTION MONEY : To be refunded to the Contractor Thirty days after the end of Defects Liability period.
8. INCOME TAX DEDUCTION : At prevailing rate from each bill
9. DEFECTS LIABILITY PERIOD : Six months from the date of completion.
10. PERIOD OF FINAL MEASUREMENT : Fifteen days after virtual completion of work.
11. DEVIATION LIMIT OF THE QUANTITIES : plus 20% of scheduled quantities
12. REFUND OF EMD : Acceptance of final bill submitted by the contractor

## CONTENTS

### TECHNICAL BID

Section - I	Invitation to Tenderers
Section - II	Instructions to Tenderers
Section - III	General Conditions of Contract
Section - IV	<b>Special Conditions of Contract</b>
Section - V	List of approved Materials

### FINANCIAL BID (separately given)

Section - VI	Schedule of Quantities and Drawings
--------------	-------------------------------------

## SECTION - I INVITATION TO TENDERERS

- 1.1 Sealed tenders in two bid system are invited from established experienced contractors by the Manager (Estate), The Oriental Insurance Company Ltd. A-25/27, Asaf Ali Road, New Delhi - 110 002.

S.No.	Name of Work	Estimated Value of Work (Rs.)	Time of Completion
1.	<b>Proposed Repair, Maintenance and Rain Water Harvesting Works For Residential Flats at- 103 A TO 112 A, SEC-27, NOIDA UP.</b>	9.32 LAC.	90[ Ninty days ]
1.2	The intending contractors may collect the tender documents from the office of Manager (Estate), The Oriental Insurance Company Ltd. A-25/27, Asaf Ali Road, New Delhi-110002 on payment of Rs. <b>500/-</b> in form of ...cash / Draft, Demand Draft from a nationalized...In favour of "THE ORIENTAL INSURANCE Co. Ltd." Payable at Delhi' from <b>5-11-2012 to 19-11-2012</b> between <b>10:00</b> hrs to <b>15:00</b> hrs. and shall be received back on or before <b>20-11-2012</b> before <b>14:50</b> hrs.		
1.3	Tenders are invited into two bid system i.e. "Technical bid" and "Financial bid". The intending contractors should submit the following details in the technical bid duly contained in closed sealed envelope no. 1 superscribed as " <b>Technical bid</b> ": a. Organisational setup <b>b. Proof of financial capability (proof from bankers for execution of the projects within a period of Sixty days)</b> c. Copy of Permanent account number (PAN) d. Copy of registration with Work Contract Tax department e. I.) Average Annual financial turnover, balance sheet duly certified by the chartered accountant shall be submitted during the last 3 years, ending 31 <sup>st</sup> March of the previous financial year, The turnover should be at least 30% of the estimated cost of the proposed project. II.) Completion certificate of successful completion of similar works from the client shall be submitted. The works executed during last 7 years ending last day of month previous to the one in which applications are invited should be either of the following. a.) Three similar completed works costing not less than the amount equal to 40% of the estimated cost. (or) b.) Two similar completed works costing not less than the amount equal to 50% of the estimated cost. (or) c.) One similar completed works costing not less than the amount equal to 80% of the estimated cost. iii) Definition of "similar work" means civil / Interior work. f. Details of projects in hand with name of clients, addresses & phone nos., g. Earnest money of <b>Rs. 20000/- Twenty Thousand only/-</b> h. In the form of Demand Draft from a bank in favour of " <b>The Oriental Insurance Co. Ltd.</b> ". payable at Delhi. The Earnest Money will be refunded without any interest to all the unsuccessful tenderers after the award of the work subject to the relevant provisions in the tender documents. Any false information furnished by the contractor shall lead to the forfeiture of the earnest money.		
1.4	The "Financial bid" shall be contained in a closed sealed envelope no. 2 superscribed as " <b>financial bid</b> ". The financial bid shall contain <b>Section-VI (Schedule of Quantities)</b> duly filled in by the intending tenderers. This shall form the part of the agreement.		

- 1.5 Both the sealed envelopes of “Technical bid” and “financial bid” should be kept in envelope no. 3 sealed and superscribed with the name of work on the top of envelope shall be deposited in the office of the Manager (Estate), The Oriental Insurance Company Ltd. A-25/27, Asaf Ali Road, New Delhi-110002, on or before **20-11-2012** before **14:50** hrs. The tender received in any manner other than prescribed above shall be summarily rejected. The company will not accept any responsibility for the tender lost in transit. The tenderer’s are asked to visit, inspect / Carefully the site. The Copies of the set of detail drawings can also be seen at the Head office of The OIC.
- 1.6 At first instance technical bid shall be opened on **20-11-2012, 15:00** hrs. The technical bid will then be evaluated on the basis of documents/information furnished as also if necessary, after physical examination of the tenderers office/workshop & projects successfully executed by them. The criteria followed by the company will be at its sole discretion and will not be open to question. The contractors who shall qualify in the technical bid will only be eligible for the opening of their financial bid.
- 1.7 Date of commencement of the work shall be reckoned from the 10th day of award of work.
- 1.8 The work as detailed in this tender shall be executed and completed in all respects in accordance with the Tender documents, which includes instructions to tenderers, General conditions of contract, special conditions of contract, schedule of Quantities, list of approved materials and Drawings to complete satisfaction of the Architects and the Employer.
- 1.9 Rates must be quoted for complete work at site inclusive of all costs, taxes and charges etc. All taxes and duties including Sales Tax on work contract. ESI charges etc. as applicable at New Delhi/NCR on the date of receipt of tender, Central & State Sales Tax, Octroi, Royalties etc. on works and materials required for use in the execution of this project shall be entirely borne and payable by the Contractor and the Employer will not entertain any claim what so ever in this respect.
- 1.10 The tender for the works shall remain open for acceptance for a period of 60 days from the date of opening of tenders. If any Tenderer withdraws his tender before the said period or makes any modifications in terms & conditions of the tender which are not acceptable by the company, then the company, shall without prejudice to any other right or remedy, be at liberty to forfeit 100% of the earnest money as aforesaid.
- 1.11 **Total Security Deposited during execution of work shall comprise of**
- (a) Earnest Money Deposit
  - (b) Retention Money
- 1.12 **Retention Money**  
The retention money (i.e. deduction from interim & final bill shall be 10% of the gross value of each. The retention money & earnest money shall form the total security deposit during execution of work. The retention amount will be refunded to the contractor after the end of Defect Liability Period provided he has satisfactorily carried out all the works and attended to all defects in accordance with the condition of contract. No interest is allowed on retention money & earnest money. Earnest money shall be refunded after the submission and acceptance of final bill.
- 1.13 Earnest money of the successful tenderer is liable to be forfeited in the event of refusal or delay on his part in signing the agreement or starting the work as mentioned in the tender and employer will be at liberty to award it to another contractor.

- 1.14 The Manager (Estate), on behalf of the competent authority, The Oriental Insurance Company Ltd. A-25/27, Asaf Ali Road, New Delhi-110002 reserves to himself the right of accepting the whole or part of the tender and the tenderer shall be bound to perform the same at the rate quoted.
- 1.15 Canvassing whether directly or indirectly in connection with the tender is strictly prohibited and the tenders submitted by the contractors who resort to canvassing in any form would be liable to rejection.
- 1.16 The tendering firms, in case the tenderer is a partnership firm, shall submit the tender signed by the partners. In the event of absence of any partner, it must be signed on his behalf by a person holding power of attorney which shall be attached along with the tender and it must also disclose that the contractor is duly registered under the Indian partnership Act or not.
- 1.17 The notice inviting tender shall form part of the contract document. The successful tenderer/contractor, on acceptance of his tender by the Accepting Authority, shall within 10 days from the stipulated date of start of work sign the contract consisting of :
- a) The notice inviting tender, all the documents including additional conditions, invitation of tender and acceptance thereof together with any correspondence leading there to.
  - b) Offer in standard tender form.
- 1.18 The tenderer shall unconditionally accept terms & conditions of the company. Conditional offer shall be summarily rejected.

**MANAGER (Estate)**

for **THE ORIENTAL INSURANCE CO. LTD.**  
**Asaf Ali Road, New Delhi-110002**

**STANDARD TENDER OFFER**

**THE ORIENTAL INSURANCE CO. LTD., ASAF ALI ROAD, NEW DELHI**

**Item Rate Tender & Contract for Works**

**Tender for the Proposed Repair, Maintenance and Rain Water Harvesting Works  
For Residential Flats at- 103 A TO 112 A, SEC-27, NOIDA UP.**

•

To be submitted by ..... between ..... hrs. to ..... hrs.

Issued to: .....

Signature of the person issuing the documents: .....

Designation: .....

Date of Issue: .....

**TENDER**

I/We have read and examined the notice inviting tender, Schedule, specifications applicable, Drawings & Designs, General rules and Directions, Conditions of Contract, clauses of contract, Special conditions, Schedule of Quantities & other documents and Rules referred to in the conditions of contract and all other contents in the tender document for the work.

I/We hereby tender for the execution of the work specified for the Manager (Estate), The Oriental Insurance Company Ltd., Asaf Ali Road, New Delhi within the time specified in schedule, viz., schedule of quantities and in accordance in all respects with the specifications, designs, drawings and instructions in writing referred to in General Rules and Directions and the Conditions of contract and with such materials as are provided for, by, and in respects in accordance with, such conditions so far as applicable.

We agree to keep the tender open for Sixty days (60 days) from the due date of submission thereof and not to make any modifications in its terms and conditions.

A sum of Rs. **20000/- Twenty Thousand only/-** is hereby forwarded in the form of Demand Draft of Bank as earnest money. If I/we, fail to commence the work specified I/we agree that the said Manager (Estate), The Oriental Insurance Company Ltd., Asaf Ali Road, New Delhi or his successors in office shall without prejudice to any other right or remedy, be at liberty to forfeit the said earnest money absolutely otherwise the said earnest money shall be retained by him towards security deposit to execute all the works referred to in the tender documents upon the terms and conditions contained or referred to therein and to carry out such deviations as may be ordered, upto maximum of the percentage 20% mentioned in the schedule and those in excess of that limit at the prevailing market rates/tendered rates whichever is lower of the two and shall be determined in accordance with the provision contained in the tender form.

I/We hereby declare that I/we shall treat the tender documents drawings and other records connected with the work as secret/confidential documents and shall not communicate information/derived therefrom to any person other than a person to whom I/we am/are authorised to communicate the same or use the information in any manner prejudicial to the safety of The Oriental Insurance Company Ltd..

I/We agree that should I/we fail to commence the work specified in the above memorandum, an amount equal to the amount of the earnest money mentioned in the form of invitation of tender shall be absolutely forfeited to the Manager (Estate), The Oriental Insurance Company Ltd., Asaf Ali Road, New Delhi and the same may at the option of the Manager (Estate) on behalf of the competent authority, The Oriental Insurance Company Ltd., Asaf Ali Road, New Delhi be recovered without prejudice to any other right or remedy available in law out of the deposit in so far as the same may extend in terms of the said bond and in the event of deficiency out of any other money due to me/us under this contract or otherwise.

Dated.....

**Sign. of Contractor**  
Postal Address

**Witness:**

Address:

Occupation:

**ACCEPTANCE**

The above tender (as mentioned by you as provided in the letters mentioned hereunder) is accepted by me for and on behalf of the Manager (Estate), The Oriental Insurance Company Ltd., Asaf Ali Road, New Delhi for a sum of Rs. .... (Rupees .....

.....  
.....)

The letters referred to below shall form part of this contract Agreement:

- a)
- b)
- c)

**for & on behalf of the Manager (Estate), The Oriental Insurance Company Ltd., Asaf Ali Road, New Delhi.**

Dated ..... Signature/Designation.....



## SECTION-2: INSTRUCTION TO TENDERERS

- 2.1 The tenderer shall examine carefully all the tender documents consisting of:

### **TECHNICAL BID**

Section - I	Invitation to Tenderers
Section - II	Instructions to Tenderers
Section - III	General Conditions of Contract
Section - IV	Special Conditions of Contract
Section - V	List of approved Materials

### **FINANCIAL BID** (separately given)

Section - VI Schedule of Quantities and Drawings

These shall form part of the agreement.

The tenderer is advised to visit and inspect the site at his own cost and responsibility and to secure all necessary information which may be required for completing the tender. Ignorance of site conditions or local information shall not be considered as an excuse for non-performance of the contract. All costs, charges and expenses that may be incurred by the tenderer in connection with the preparation of his tender shall be borne by him and the Employer/Architect does not accept any liability whatsoever in this regard.

- 2.2 Time is the essence of the contract and the tenderers are required to complete the work in all respects within the stipulated time of completion and hand over the same, complete in all respects to the satisfaction of the Architects/Employer.
- 2.3 The tender should contain not only the rates but also the value of each item of work entered in the prescribed column of the BOQ and all the items should be totaled up in order to show the aggregate value of the entire tender. The rates quoted by the tenderer should be expressed accurately both in words and figures so that there is not discrepancy. All corrections in the tender shall be duly attested by initials of the tenderers. Corrections if not attested, may entail rejection of tender. The rates quoted by the tenderers in item rate tender will be the basis (and not the amounts in case of discrepancies) in finalising the tender.
- 2.4 It shall be clearly understood that the rates quoted in the tender are to be for complete work at site as per instructions to tenderers, conditions of contract, special conditions of contract specifications and drawings, addenda referred to therein and also for all such work's as are necessary for the proper completion of the contract. Although specific mention thereof may not have been made in the specifications or in drawings or in tender documents. The rates shall be firm and shall not be subject to cost escalation on account of labour and material and labour conditions or any other reason whatsoever.
- 2.5 The tenderers shall use only the form issued with this tender to fill up the rates.

- 2.6 Every page of the tender shall be signed on the bottom of right hand side and any tender not so completed is liable to be treated as defective and liable to be rejected.
- 2.7 The successful tenderer will be notified about the acceptance of his tender by the employer and he will execute agreement within 10 (ten) days thereof, failing which his tender would be liable to rejection with forfeiture of the Earnest Money and the employer would be at Liberty to award it to another tenderer.
- 2.8 The contract will be governed by the Indian Contract Act, Indian Sale of goods Act and all other relevant laws. All payments due to the contractor under the contract will be made in Indian Rupees Currency.
- 2.9 The rates quoted shall be for complete work at site and should be inclusive of incidentals expenses necessary for carrying out the work. The rates shall be inclusive of Sales Tax if applicable at the place of execution of work. for or any other tax or duty levied by any Government or Public bodies. The rates shall be firm and shall not be subject to cost escalation of labour and material and exchange variations, labour conditions or any other conditions whatsoever.
- 2.10 A schedule of approximate quantities for various items accompanies this tender. It shall be clearly understood that neither the architect nor the employer accept any responsibility for the correctness or completeness of this schedule in respect of items and quantities and this schedule is liable to alterations by omission, deduction or additions at the discretion of the employer in consultation with the architect without violating the terms of the contract.
- 2.11 The employer does not bind itself to accept the lowest or any tender or to assign any reason thereof and also reserves the right of accepting the whole or part of the tender. The part acceptance will not violate the terms and conditions of the contract and will execute the work at the specified rates without any extra charges or compensation.
- 2.12 Tax deductions will be made as per the prevailing rates from the contractors on account bills.

## SECTION III - GENERAL CONDITIONS OF THE CONTRACT

### 3.1.0 DIRECTIONS REGARDING PROCEDURES

In construing these conditions, specifications and Contract Agreement, the following words shall have the meaning here in assigned to them except where the subject or context otherwise requires:

- (a) "Employer" Shall mean "oriental Insurance Co. Ltd.", having its office at A-25/27, The oriental House, Asaf Ali Road, New Delhi-1 shall include authorized representative/s assign/s or successor/s.
- (b) "Contractor/Builder" Shall mean the individual or firm or company, whether incorporated or not, undertaking the work and shall include legal personal representatives of such individual or the persons comprising such firm or company or the successors of such individual or firm or company and the permitted assignee of such individual or such individual or firm or company.
- (c) "Architect" Shall mean the said whose registered office is situated at Architects: **A.V. ARCHITECTS**, JG-III, 65-A, Ground Floor, Vikaspuri, New Delhi-110018, (and shall include his authorised representative) or in the event of his death or termination of his services by the Employer in his sole and unqualified discretion, such other person/persons as shall be provided always that no person subsequently appointed to be Architect under this contract shall be entitled to disregard or over rule any previous decision or direction given or expressed by the Architect specified here in unless otherwise approved by the Employer.
- (d) "Project Manager" Shall mean the accredited representative of the Employer and shall be over all in-charge of the work. He shall administer the contract as per contract Agreement conditions.
- (e) "Contract" Means the documents forming the tender and acceptance thereof and the formal agreement executed between the the Manager (Estate), on behalf of competent authority "The Oriental Insurance Company Ltd.", Asaf Ali Road, New Delhi and the Contractor, together with the documents referred to therein including these conditions, the specifications, designs, drawings and instructions issued from time to time by the Engineer-in-Charge and all these documents taken together, shall be deemed to form one contract and shall be complementary to one another.

In the contract, the following expressions shall, unless the context otherwise requires have the meanings, hereby respectively assigned to them:

- (i) The expression **works** or **work** shall, unless there be something either in the subject or context repugnant to such construction, be construed and taken to mean the works by or by virtue of the contract contracted to be executed whether temporary or permanent, and whether original, altered, substituted or additional.
- (ii) The **site** shall mean the land/or other places on, into or through which work is to be executed under the contract or any adjacent land, path or street through which work is to be executed under the contract or any adjacent land, path or street which may be allotted or used for the purpose of carrying out the contract.
- (iii) **Schedule(s)** referred to in these conditions shall mean the relevant schedule(s).
- (iv) **Tendered Value** means the value of the entire work as stipulated in the letter of award of work.

### 3.1.1 General

The work shall be carried out strictly in accordance with the drawings amplified by the specifications of materials and workmanship given hereunder. The drawings and specifications shall be taken together and shall complement each other. In case of any discrepancy, the following order of preference shall be followed:

- (a) Particular Specifications.
- (b) Drawings.
- (c) CPWD Specifications & Latest DSR on date of Publication of the tender.
- (d) National Building Code and Relevant IS Provisions.

In case there are no specifications for items shown on the drawings or where items are not exhaustively described, the general specifications of CPWD shall be followed for which nothing extra shall be paid. However the specification should be got approved from the Architect before commencement of work.

### 3.1.2 Drawings and Specifications

- (a) After signing the Contract, the contractor will be given free of charge three prints of all working drawings. The contractor shall make at his own expense any additional copies he requires. One copy of the drawing furnished to the contractor as aforesaid shall be kept by the contractor at site and the same shall, at all reasonable times be available for inspection and use by the Architect and his representatives or by any other person authorized by him in writing.

- (b) Such further drawings and instructions including revisions, as the Architect may furnish to the Contractor shall from part of this contract.
- (c) Only figured dimensions and detailed drawings shall be followed. The Contractor shall verify all dimensions in the field before any work is started and obtain instructions of the Architect in case of any discrepancy.
- (d) The Architect with approval of the project manager shall have power and authority to supply to the Contractor from time to time during the progress of the work, such further drawings and instructions as shall be necessary for the purpose of proper and adequate execution and maintenance of work and the Contractor shall carry out and be bound by the same.

### **3.1.3 Architects Status and Decisions**

- (a) Status:

The Architects shall have general supervision and direction of the work. He has authority on behalf of the Employer to stop the work whenever such stoppage may be necessary to ensure the proper execution of the work. The architect shall be the interpreter of the conditions of contract and the judge of its performance subject to the approval of the Project Manager.

- (b) Decisions:

The Architect shall, within a reasonable time, make decisions on all claims of the contractor and on all other matters relating to the execution & progress of the work or the interpretation of the contract documents. The decisions, opinion direction of the Architects with respect to all or any of the following matters shall be referred to the Project Manager and decision so taken shall be final & binding to the contractor.

- i) Variation or modifications of the design.
- ii) The quality or quantity of works or the additions/alterations or omissions or substitutions of any work.
- iii) Any discrepancy in the drawings or between the drawings and or specifications.
- iv) The removal and / or re-execution of any work by the contractor.
- v) The dismissal from the work of any persons employed therein.
- vi) The opening up for inspection of any work covered up.
- vii) The amending the making good of any defects under defects liability period.
- viii) Approval of materials and workmanship.

- ix) The contractor to provide every thing necessary for the proper execution of the work.
- (c) The authorities so conferred in the architect vide various clause above shall be subject to review of the Project Manager at any time whenever desired & his reviewed decision shall binding under the contract.
- (d) The employer shall be at liberty to take over the project at any time get the work executed directly under the supervision of Project Manager. The power vested in the Architect under this tender shall automatically be vested in the Project Manager thereafter.
- (e) In the event of any dispute under this contract or between the Architect & the contractor, the speedier decision will be final in the matter. In case the contractor refer the matter to the Project Manager for speedier decision.
- (f) Dismissal:

The contractor shall on the report of the architects immediately dismiss from the works within 24 hours any person employed thereof by him, who may, in the opinion of Architects be incompetent or misconducts himself and such person shall not be re-employed on the works without the permission of the Architects.

### **3.2.1 Extent of Contract**

The contractor shall supply at his own cost all material implements, ladders, cordage, tackle, scaffolding and temporary works required for the proper execution of the work whether original, altered or substituted and whether included in the specifications or other documents forming part of the contract or referred to in these conditions or not and which may be necessary for the purpose of satisfying of conditions he is entitled to be satisfied which he is entitled to require together with carriage therefore to and from the work. The contractor shall also supply survey instruments and other materials necessary for the purpose of setting out works, and counting weighing and assisting to the measurement or examinations at the any time and from time to time of the work material, falling his so doing the same may be provided by the engineer-in-charge at the expense of the contractor and the expenses may be deducted from any money due to the contractor under the contract from his security deposit or the proceeds of sale thereof. The contractor shall also provide a sufficient portion of fencing and lights required to protect the public from accident, and shall be bound to bear the expenses of defence brought by any person for injury sustained owing to neglect of the above precautions and to pay any damage and costs which may be awarded in any such suit, action or proceedings to any such person or which may with the consent of the contractor be paid to compromise any claim by any such person. In no case, the employer shall be as a party to any such claim/claims and the contractor shall indemnify the employer against any claim for any person on this account.

### **3.2.2 Sufficiency of Tender**

The contractor shall be deemed to have satisfied himself before tendering to the correctness and sufficiency of his tender for the work and of his prices for the work and of his prices stated in the schedule, which shall, except in so far as it is otherwise provided in the contract, cover all his obligations under the contract and all matters and things necessary for the proper completion and maintenance of the work.

### **3.2.3 Assignment or Sub Letting of Contract**

The contractor shall not assign the contract or any part thereof or any benefit or interest therein or there under or any claim arising out of the contract to any other party without the prior written consent of the employer.

### **3.2.4 Power to make Alterations**

Architect shall have power to make any alterations or additions to the stipulated specifications, drawings, designs, and in striations that may appeal to him to be necessary or, advisable during the progress of the work and the contractor shall have no claim for compensation on account of such alterations or additions. The contractor shall be bound to carry out the work in accordance with any instructions which may be given to him in writing signed by the Architect and such alterations shall not invalidate the contract and any additional work which the contractor may be directed to do in the manner above specified as part of the work shall be carried out by the contractor on the same conditions in all respects on which he agreed to do the main work and at the same rates as are specified in the tender for the main work. The time for the completion of the work shall be extended in the proportion that the additional work bears to the original contract work and the certificate of the Architect/Project Manager shall be conclusive as to such proportions.

### **3.3.0 WORKS SUBJECT TO APPROVAL OF ARCHITECT**

All works to be executed under the contract shall be subject to approval of the architect who shall be entitled to direct at what point or points and in what manner they are to be commenced and from time to time carried on.

#### **3.3.1 Contractors office and Stores**

All offices, sheds and stores required by the contractor shall be enacted at his own cost with the prior approval of the Project Manager or his representative and shall be dismantled and removed upon the completion of the work if so directed within 7 (seven) days of the issue of such intimation.

#### **3.3.2 Urgent Repairs and Urgent works**

If by reason of any accident or failure or other event occurring to or in connection with the work or any part thereof either during the execution of the work or during the period of Guarantee, any remedial or other work or repair shall in the opinion of Project Manager be urgently necessary for security and the contractor is unable or unwillingly at once to do such work or repair, the employer may on its own get the

work done/remedied/repared as the Resident Engineer may consider necessary. If the work or repair so done by the employer is such, which, in the opinion of the Architect the contractor was liable to do at his own expense under the contract, all costs and changes incurred by the employer in doing so shall on demand be paid by the contractor to the employer or may be deducted by the employer from any money due or which may become due to the contract. Provided always that the resident engineer shall soon after the occurrence of any such emergency as may be reasonable notify the contractor thereof in writing.

### **3.4.0 DIRECTION FOR EXECUTION OF WORK**

#### **3.4.1 Setting outs**

The contractor shall be responsible for the true and proper setting out of the works in relation to the original points, lines and levels of reference given by the architect in writing and for correctness subject as above mentioned of all the positions, levels dimensions and alignments of all parts of the work and for the provision of all necessary instruments, appliances and labour in connection therewith. If at any time during the progress of the work any error shall appear or arises in any part of the work, the contractor on being required to do so by the Project Manager shall at once inform the architect or their representatives. The checking of the work by the architect/representative shall not in any way relieve the contractor from his responsibilities of carrying out the work as per the best practises of construction.

#### **3.4.2 Work to be to the satisfaction of the Architect**

The contractor shall execute, complete and guarantee the work in accordance with the contract to the satisfaction of the architect and shall comply with the adhere to their instructions & directions concerning the work.

#### **3.4.3 Engagement of Labour**

The contractor shall employ labour in sufficient numbers either directly or through subcontractors, where such sub letting is permitted to maintain the required rate of specified in the contract and to the satisfaction of the architect. The contractor shall not employ in connection with the works any person who has not completed his fifteen years of age.

The contractor shall comply with the provisions of the payment of Wages Act, 1936; Minimum Wages Act, 1948; Act, 1947; Maternity Benefit Act, 1961 and Mines Act, 1938, Labour Contract (Regulations & Abolishing) Act or Rules, or any modifications thereof or any other law relating thereto and rules made there under time to time.

The contractor shall indemnify the employer against any payment to be made under and for observance of the Regulation aforesaid without prejudice to his right to claim indemnify from his sub-contractors.

The contractor shall provide and maintain at his own expenses all rights, guards, fencing and watching when and where necessary or required by the Resident



Engineer for the protection of the works or for the safety and convenience of those employed on works or the public.

#### **3.4.4 Disruption of Progress**

The contractor shall give written notice to the Architect whenever planning or progress of the works is likely to be delayed or disrupted unless any further drawings or order, including a direction, instruction or approval is issued by the Architect within a reasonable time. The notice shall include details of the drawing or order required and by when if is required and of any delay or disruption likely to be suffered if it is late.

If, by reason of any failure or inability of the Architect to issue within a time reasonable in all the circumstances any drawings or order requested by the contractor and the work suffers delay then the architects shall take such delay into account in determining any extension of time to which the contractor is entitled under provisions of contract hereof, however no other compensation will be admissible on this account.

#### **3.4.5 Rectification of Defects**

if, it shall appear to the Architect or his representative in-charge of the works that any work has been executed with unsound, imperfect or un-skillful workmanship or material or any inferior description, the contractor shall, on demand, in writing from the Architect specifying the work material or articles complained of rectify or remove and carryout reconstruction work so specified in part, as the case may require.

#### **3.4.6 Variation**

In case the quantity of any item of the work executed increases by more than 20% from the quantity given in the tender document, the rate of such item would be settled as under:

- a) Rate of the item worked out as per market rate
- b) Rate of the item quoted by the contractor.

The rate of such item would be lowest of the two rates mentioned above.

**3.4.7** The contractor shall submit the samples of various material for the approval of the Architect & Client. The contractor shall use the material only after the approval of the Architect/Client. The verification of the material shall be done on random base during the progress of the work in either the following manner :

- (a) Random samples would be picked up during execution of work from site & if decided by the Architect/client, it would be sent to one of the approved laboratories for test & quality check. The cost of such tests would be borne by the client.
- (b) The Architect/client may direct the contractor to submit the challan of delivery of the material brought at site. It would be on Random based. The Architect

may also direct the contractor to submit the copy of the test/verification certificate provided by the manufacturer of that particular material.

#### **3.4.8 Free Access to work site**

The contractor shall provide all necessary and reasonable facilities and free access to the works and his records at site of work to the Architects, Resident Engineer and their representatives. He shall provide facilities and space to the satisfaction of the Architect or his representative for inspection of any part of work.

#### **3.4.9 Inspection of work**

All work under or in course of execution or executed in pursuance of the contract shall at all times be open to inspection and supervision of the Architect or his representative and the contractor shall at all times will be present & note the instructions of architect / his representative he, either himself shall be present to receive orders and instructions, or his responsible agent duly accredited in writing shall be present for that purpose. Orders to the contractor's agent shall be given by the contractor himself.

#### **3.4.10 Preparation of Construction Programme Schedule**

As and when sufficient planning information is available, the contractor in consultation with the Architect shall prepare a programme schedule of the activities. Contractor should prepare bar-charts & articles path method analysis of the light of the tendered quantities and their rates respectively. Under no circumstances shall this schedule be prepared later than one week of finalisation of contract. Throughout the work, all programmes, schedules and charts shall be revised wherever any significant change occurs. The contractor shall also submit weekly progress chart to the Architect.

#### **3.4.11 Site Order Book**

The contractor shall maintain a Site Order Book at the site of the works wherein the instructions of the architect/Project Manager or their representatives shall be reasoned. The site order book shall be the property of the employer and the instructions recorded therein shall be deemed to have the same force and effect as if they had been given to the contractor himself. The contractor or his representative on the site must sign the book in token of his having persuade the orders given therein.

#### **3.4.12 Hindrance Register**

A Hindrance Register shall be maintained at the site of work wherein the contractor shall notify the items affected and the execution of work, the date on which the delay was cleared. These entries shall be initiated by the Project Manager/Architect as well.

### **3.4.13 Suspension of Work**

The contractor shall on the written order of the Architect/Project Manager suspend the progress of the work or any part thereof for such time or time and in such a manner as the Architect/Project Manager may consider necessary and shall during such suspension properly protect and secure the work as considered necessary in the opinion of the architect/Project Manager or their representative-in-charge of the work. No compensation shall be payable to the contractor on what so ever account for the suspension of work.

### **3.4.14 Extension of time for completion**

If the contractor shall desire an extension of the time for completion of the work, on his having been unavoidably hindered in its execution or on any other ground, he shall apply in writing to the architect within three days of the date of starting of the hindrance on account of which he desires such extension as aforesaid. The architect in consultation with employer shall, if, in his opinion, will authorise, such extension of time, if any, as may in his opinion be necessary or proper extension granted shall be without prejudice to the right of the Employer to recover compensation for delay as per **provisions of Para 3.4.15**

### **3.4.15 Liquidated Damages for Delay**

The times and date stipulated in the contract for the completion of the work or any part or stage thereof shall be deemed to be the essence of the contract.

The work shall, throughout the stipulated period of the contract, be carried out with all diligence. If the contractor fails to complete the work within the time prescribed or within the extended time under the contract, he shall pay to the Employer on demand amount without prejudice to other rights and remedies the Employer may have against the contractor, a sum of Rs. 2000/- per day as liquidated damages for such fault, if the work remain unfinished after the stipulated date of completion provided that the total liquidated damages payable shall not exceed 10% of the accepted contract price. The Employer may, without prejudice to any other method of recovery, deduct the amount of such damages from any money due or which become due to the contractor. The recovery or deduction of such damages shall not relieve the contractor from any obligations and liabilities under the contract.

### **3.4.16 Defects Liability Period**

The contractor shall be responsible to make good and remedy at his own expense within such period as may be stipulated by the employer any defect which may develop or may be noticed before the expiry of 6 (six) months from the date of completion and intimation of which has been sent to the contractor within seven days of the expiry of the said period.

If the contractor or his work people, or servants shall break, deface, injure, or destroy any part of a building, or interiors, then the contractor has to rectify the same part at his own expenses to the satisfaction of the Architect.

### **3.4.17 Approval of Materials**

The contractor would bring samples of necessary materials per the directions & would get them approved prior to execution of work.

## **3.5.0 SECURITY DEPOSIT**

### **3.5.1 Rate of Security Deposit (Retention Money)**

The employer will, at the time of making any payment to the contractor for work done or supply made under the contract deduct 10% of Gross value of each interim bill. The maximum amount of Retention money + Earnest Money shall amount to total Security Deposit.

All compensations or other sums of money payable by the contractor to the employer in terms of this contract may be deducted from, or paid by, the sale of a sufficient part of his security deposit, or from any sums which may become due to the contractor by the employer on any account whatsoever, and in the event of his security deposit being reduced by reason of any such deduction or sale as aforesaid, the contractor shall within ten days. Thereafter make good in demand draft, endorsed in favour of the employer as aforesaid any sum or sums which may have been deducted from, or raised by sale of his security deposit or any part thereof.

### **3.5.2 Forfeiture of Security Deposit**

The above said security deposit shall be liable to forfeiture wholly or in part at the sole discretion of the Employer if the contractor fails to carry out the work or perform or observe any of the conditions of the contract.

### **3.5.3 Interest on the Security Deposit**

No interest would be payable by the employer to the contractor on the security held in deposit.

### **3.5.4 Responsibilities for the Structural Adequacy**

The contractor shall comply with the provisions of the contract and with due cares and diligence, execute and maintain the work and provide all labour, including supervision of all works, structural plans and other things whether of temporary or permanent nature required for such execution and maintenance in so far as the necessary for providing these, is specified or is reasonably inferred from the contract. The contractor shall take full responsibilities for the adequacy, suitability and safety at site of all the works and methods of the construction provided.

### **3.6.0 MEASUREMENT AND PAYMENTS**

**3.6.1** All bill supported with measurement details shall be submitted by the contractor fortnightly to the Architect for all works executed in the previous period and the Architect/Project Manager or his representative shall verify the requisite measurement for the purpose of having the same verified for the claim as far as admissible, if possible before the expiry of 15 days from the presentation of the bill.

All measurements to be taken in duplicate and all bills shall be submitted in triplicate along with a contractor's copy of each.

### **3.6.2 Final Bill**

Final bill supported with consolidated measurement of the full work executed shall be submitted by the contractor within 1 month of completion of work.

When the final bill has been verified and corrected, the architect will give seven days notice to the contractor to countersign the bill in token of acceptance, the contractor shall countersign the bill within the above seven days or intimate in writing his intention to dispute. If the contractor fail to take appropriate action as above within the period prescribed, the bill finalised by the architect or his representative shall be final and binding on the contractor and the contractor shall have no right to dispute the same.

### **3.6.3 Claim for Interest**

No claim for interest will be entertained by the Employer with respect to any moneys or balances which may be in its hands owing to a dispute between itself and the contractor or with respect of any delay on the part of the employer in making interim or final payments or otherwise.

### **3.6.4 Rates for extra Additional, Altered or Substituted work**

The rates for additional, altered or substituted work shall be worked out in accordance with the following provisions in their respective order.

- i) If the rates for similar additional, altered or substituted work and directly available in the contract for the work, the contractor is bound to carry out the work at the same rates as are available in the contract for the work.
- ii) If the rates for additional, altered or substituted work are not directly available in the contract for the work the rates will be derived from the rates for a similar class of work as are specified in the contract for the work.

- iii) If the rates for the altered, additional or substituted work cannot be determined in the manner specified in sub-clause (I) to (ii) above, then the contractor shall within three days of the date of receipt of order to carry out the work, inform the Architect of the rate which it is intended to charge for such works supported by analysis of the rate or rates claimed. Rates finalised and approved by the Architect on the basis of these details will be final and binding. However, the architect by notice in writing will be at liberty to cancel his order to execute such work and arrange to carry it out in such a manner as he may deem advisable, but under no circumstances shall the contractor suspend the work once ordered in writing on the plea of non-settlement of rate.

### **3.6.5 Reimbursement of Variation in Price**

Prices and rates quoted by the bidders shall be considered as firm for the complete work and entire duration of the contract. No claim for extra payment due to any rise in rates of raw material and labour or due to whatsoever reasons, shall be considered, not even for extended period of completion.

### **3.7.0 GUARANTEES**

#### **3.7.1 Quality of Work**

The contractor shall guarantee that the materials and workmanship are the best of their respective kinds for the service intended and that all items of work will be free from all inherent defects in workmanship and materials. He shall also guarantee that the works will not fail in any respect due to quality of materials, workmanship and methods of construction.

The specifications assume a proper degree of skill on the part of contractor and workmen employed. The contractor shall consult the Architect or his representative, whenever in his judgment variation in the methods of construction or in the quality of material would be beneficial or necessary to fulfill the guarantee called for. Such variations may be made by the contractor only when authorised by the architect.

#### **3.7.2 Rejection**

If during the "Period of Guarantee", as defined under clause 3.7.6 hereof, any work or material shall fail in any respect to meet the above guarantee, the contractor shall replace such work or material in a condition which will meet the above guarantee, immediately.

#### **3.7.3 Cost of Execution of work or repair etc.**

All work of repair shall be carried out by the contractor at his own expense if the necessity thereof shall in the opinion of the Architect be

due to the use of materials or workmanship not in accordance with the contract or on account of neglect or failure on the part of the contractor to comply with any obligation expressed or complied on the contractor's part under the contract.

#### **3.7.4 Remedy on Contractor's failure to carry out the work required**

If the contractor shall fail to do any such work as aforesaid required by the architect the employer shall be entitled to carry out such work which the contractor should have carried out, at the contractor's own cost. The employer shall be entitled to recover from the contractor the cost thereof or may deduct the same from any money due or that may be come due to the contractor.

#### **3.7.5 Certificate of completion of works**

On completion of the work, the contractor shall be furnished with a certificate, but not such certificate be given nor shall the work be considered as complete until the contractor shall have removed from the area of the premises (to be distinctly marked by the Architect/Project Manager in the site plan which, the work shall be executed) all scaffolding, surplus materials and rubbish and clean the dirt from all wood work, doors, windows, walls, floors or other parts of any building, in or upon which the work is to be executed, or of which he may have had in possession for the purpose of the execution hereof. If the contractor shall fail to comply with the requirements of the clause as to the removal of scaffolding, surplus materials and rubbish and cleaning off dirt on or before the date fixed for the completion of the work, the architect may at the expense of the contractor remove such scaffolding, surplus materials, and the contractor shall forthwith pay the amount of all expense so incurred, and shall have no claim in respect of any such scaffolding or surplus materials aforesaid, except for any sum actually realized by the sale thereof.

#### **3.7.6 Period of Guarantee for Complete work**

The period of Guarantee for the works shall be **six** month starting from the date of issue of the completion certificate.

#### **3.7.7 Contract Valid during Guarantee Period**

This contract shall remain valid and in force until the expiry of Guarantee period.

#### **3.8.0 RESCINDING/TERMINATE CONTRACT**

##### **3.8.1 Rescinding Contract**

In any case in which under any clause or clauses of this contract the contractor has rendered himself liable to pay compensation amounting to the whole of his security deposit in hand of employer (whether paid in

one sum or deducted by installments) the architect on behalf of the employer shall have power to adopt any of the following course, as deemed best suited to the interests of employer.

- (a) To rescind the contract (of which rescission notice in writing to the contractor under hand of the architect shall be conclusive evidence), and in which case the security deposit of the contractor shall stand forfeited and be absolutely at the disposal of the employer.
- (b) To employ a contractor paid by the employer and to supply materials to carry out the work, or any part of the work, debiting the contractor with the cost of the labour and the price of the materials (of the amount of which cost and price certificate of architect shall be final and conclusive against the contractor) and crediting him with the value of the work done, in all respects in the same manner and at the same rates as if it has been carried out by the contractor under the terms of the contract. The certificate of the architect as to the value of the work done shall be final and conclusive against the contractor.
- (c) To measure up the work of the contractor, and to take such part of the work of the contractor as shall be unexecuted out of his hands, and to give it to another contractor to complete in which case any expenses which may be incurred in excess of the sum which would have been paid to the original contractor if the whole work has been executed by him (of the amount of which excess certificate in writing of the architect shall be final and conclusive) shall be borne and paid by the original contractor and may be deducted from any money due to him by employer under the contract or otherwise, or from his security deposit or the proceeds of sale thereof, or a sufficient part thereof.
- (d) In the event of any of the above courses being adopted by the architect, the contractor will have no claim to compensation to any loss sustained by him by reason of his having purchased any materials, or entered into any engagements made any advances on account of execution of the work or performance of the contract. And in case of the provisions aforesaid, the contractor shall not be entitled to be paid for any work actually performed under this contract unless and until the architect shall have certified in writing the performance of such work and the value payable in respect and he shall only be entitled to be paid the value so certified.

### **3.8.2 Termination of the Contract**

If at any time after the commencement of the work the employer for any reason whatsoever does not require the whole or part thereof as specified in the tender to be carried out, Architect/ Project Manager shall give notice in writing of the fact to the contractor who shall have no claim to any payment or compensation whatsoever on account of any profit or advantage, which would have derived from the execution of the



work in full, but which he did not derive in consequences the full amount of the work not having been carried out, neither shall he have any claim nor compensation by reason of any alterations having been made in the original specification, or the designs and instruction on which shall involve any containment of the work originally contemplated.

### **3.8.3 Jurisdiction**

The contractor and its operation shall be governed by the law of India for the time being in force, irrespective of the place of delivery of materials the place of execution of work or place of payment under this contract shall be deemed to have been entered into at New Delhi.

### **3.8.4 Bye Laws of Local Authorities**

The contractor shall conform to the provisions of any Government Acts which relate to works and to the regulations and bye laws of any local authorities. The contractor shall give all such notices required by the said Act or Laws, etc., and pay all fees payable to such authorities and allow for these contingencies in his tendered rates including fees for encroachment, stacking charges, costs of restorations, etc., and all other fees payable to the local authorities. The contractor shall keep the employer indemnified against all penalties and liabilities for every kind/type of breach of any such Act, Rules, Regulations or Bye-laws.

Contractor shall comply with all laws and statutory regulations dealing with the employment of labour such as:

- a. The payment of wages Act, 1936
- b. The Minimum Wages Act, 1938
- c. The Workmen Compensation Act, 1923
- d. The Contract Labour (Regulations & Abolishing) Act.
- e. The employer's liabilities Act, 1938
- f. Industrial Dispute Act, 1938
- g. Maternity Benefit Act, 1961
- h. The Employees State Insurance Act, 1948

Safety code, labour welfare Act or rules or any modification thereof any other laws and regulations framed by the Competent Legislative Authorities from time to time.

## **SECTION IV – SPECIAL CONDITIONS OF THE CONTRACT**

### **4.1.0 Insurance for Works**

The contractor at the time of signing the contract or before commencing the execution of work, without limiting his obligations and responsibilities shall insure the works at his own cost and keep them insured until the virtual completion of the contract against all acts of God including Fire, Theft, Riots, War, Floods etc. with a Nationalised Insurance company in the joint names of the employer and the contractor (the name of the former being placed first in the policy) for the full amount of the contract. Such policy shall cover the property of the employer and fees for assessing the claim and in connection with its services generally therein and shall not cover any property of the Contractor or of any sub contractor or employee.

In addition to the above contractor would take workmen's compensation policy CPM Insurance cover and liability Insurance so as to ensure that in case of any mishap workers are rightfully compensated and any liability to T.P., which shall include employee of this employer & architect / his representative etc.,

The contractor shall deposit the policy and receipt for the premiums with the employer within seven (7) days, from the date of signing of the contract/commencement of the execution of the work or unless otherwise instructed by the employer. In default of the contractor insuring as provided above, the employer on his behalf may so insure and may deduct the premiums paid from any moneys due on which may become due to the contractor. The contractor shall as soon any claim under the policy is settled on the work reinstated by the Insurance office should elect to do so, proceed with all due diligence with, the completion of the works in the same manner as through the misfortune/accident had not occurred and in all respects under the same conditions of the contract. The contractor in case of rebuilding or reimbursement after accident shall be entitled to such extension of time for completion, as the employer deems fit.

### **4.1.1 Insurance in respect of damage to persons and property**

- a. The contractor shall be responsible for all injury to persons, animals or things and for all structural and decorative damage to property which may arise from the operation or neglect of himself or of any approved sub-contractor's or employees, whether such injury or damage arise from carelessness, accident or any other cause whatsoever in any way connected with the carrying out of this contract. The clause shall be held to include any damage to buildings, whether immediately adjacent or otherwise, and any damage to roads, streets, foot paths, bridges and works forming the subject of this contract by frost or other inclemency of the weather. The contractor shall indemnify the employer and hold him harmless damage to persons or property as aforesaid and also in respect of

any claims made in respect of injury or damage under any Acts of Government or otherwise and also in respect of any award of compensation of damages consequent upon such claims.

- b. The contractor shall reinstate all damages of every sort mentioned in this clause, so as to deliver up the whole of the contract works complete and perfect in every respect and so as to make good or otherwise satisfy all claims for damage to the property of third parties.
- c. The contractor shall indemnify the employer against all claims which may be made against the employer by any member of the public or other third party in respect of works in consequence thereof and shall at his own expense arrange to effect and maintain, until the virtual completion of the contract, with any Nationalised Insurance company in the joint name of the employer and the contractor against such risks and deposit such policy or policies with the employer from time to time during the currency of this contract. The contractor shall similarly indemnify the employer against all claims which may be made upon the employer whether under the Workman's Compensation Act or any other statute in force during the currency of this contract or at common law in respect of any employee of the contractor or any sub-contractor and shall at his own expenses effect and maintain with an approved office a policy of Insurance in the joint names of the employer and the contractor against such risks and deposit such policy or policies with the employer and the contractor against such risks and deposit such policy or policies with the employer from time to time during the currency of the contract. The contractor shall be responsible for any thing which may be excluded from the insurance policies above referred to and also for all other damages to any property arising out of and incidental to the negligent or defective carrying out of this contract. He shall also indemnify the employer in respect of any costs, charges or expenses arising out of any claim or proceedings and also in respect of any award of or compensation of damages arising therefrom.
- d. The employer shall be at liberty and is empowered to deduct the amount of any damages, compensation costs, charges and expenses arising or occurring from or in respect of any such claim or damage from any sum or sums due to or become due to the contractor including the security deposit.
- e. If the contractor fails to comply with the terms of these conditions, the employer may insure the works and may deduct the amount of the premiums paid from any moneys that may be or become payable to the contractor or may at the option, not release running payment to the contractor until the contractor shall have complied with the terms of this condition.

- f. Such insurance whether effected by the employer or the contractor will not limit or bar the liability and obligation of the contractor to deliver the works to the employer completed in all respects according to the contract. In case of loss or damage due to any of the aforesaid clause, the moneys payable under any such insurance shall be received and retained by the employer until the works are finally completed and such moneys shall then be credited to the contractor in final settlement of accounts.
- g. No incomplete works shall be accepted and nothing shall be paid to the contractor. However the part rates may be allowed to the contractor for the executed works which shall be treated as advance and recovered if the works left incomplete.
- h. USE OF WATER AND ELECTRICITY**
- I. The main contractor shall be allowed to use adequate available quantity of construction water and electricity "Free of cost" at the work site for all the legitimate works by the employers. The contractor will, however, draw water/ electricity from or designated central point with his own pipes, cables and distribution system through valves/ switches including providing small water storage tank etc. without causing any spillage and misuse. However, in case of shortage or breakdown of electricity or water supply the constructor shall make alternative arrangements at his own expense so as to ensure timely progress and completion of works.
- II. The contractor shall ensure uninterrupted supply of water, electricity, access to staff and disposal of sewage/waste to be maintained for existing occupants/within the building premises. The employer does not guarantee adequacy or continuity of electricity and water supply.
- III. Agency for electrical installations all works under Electrical services of Bill of quantities shall be carried out by licensed contracting agencies. All necessary approvals, formalities of the local and other authorities, department's etc. shall be complied with by the Main Contractor

RENOVATION WORKS FOR THE OIC LTD.  
AT 103 a to 112 a sec 27 noida up

SPECIFICATIONS/BRAND NAMES of materials and finished approved by the Architect/Employer are listed below: However equivalent materials and finished of any other specialized firms may be used , In case it is established that the brands specified below are not available in the market are subject to the approval of the alternative brand by the Architect.

S. NO.	ITEM	DESCRIPTION
1	<b>REINFORCEMENT STEEL</b>	Shall be TISCON 42 TATA iron & steel Co. Ltd. Or SAIL, RATHI tore steel
2	CEMENT	Shall be ordinary Portland cement 53 grade manufactured by Larsen & Turbo Ltd. ii)Shriram Cement by M/S Shriram Industries Ltd. iii) A.C.C. Cement by Associated Cement Companies Ltd. Pozzolona cement shall not be used.
3	AD MIXTURE FOR FAST SETTING OF CONCRETE	PIDILITE/RFFE OR EQUIVALENT
4	WATER PROOFING COMPOUND	DON.CICO,PIDILITE
5	WHITE CEMENT	J.K. WHITE CEMENT BIRLA WHITE CEMENT
6	PLASTIC PAINT	Shall be first quality ENAMEL, PLASTIC EMULSION manufactured by AND BERGER PAINTS , ASIAN PAINTS ,ICI
7	M.S . COVER	IS MAKE
8	PUTTY	Shall be gold size Putty by BIRLA./ASIAN PAINTS.
9	EXPANSION BOLTS FOR FIXING	Shall be DASH FASTENERS of appropriate size by HILTI OR M/S. DEV ASHISH TRADES OR APPROVED EQ. NEW DELHI.
10	G.I.Pipe and fittings	Tata, Jindal, Appolo
11	C.I./R.W.P.	RIF,IIS OR EQ.
12	Sanitary Ware	CERA, Hindustan, Somany ,Parry ware
13	PVC Pipe	Prince/supreme/ prakash or equivalent ISI make
14	Nahani Trap	NECO or equivalent ISI make

RENOVATION WORKS FOR THE OIC LTD.  
AT 103 a to 112 a sec 27 noida up

**Proposed Repair, Maintenance and  
Rain Water Harvesting Works**

**FOR  
RESIDENTIAL FLATS AT - 103 A TO 112 A, SEC-27, NOIDA UP.**

**THE ORIENTAL INSURANCE CO. LTD.  
ASAF ALI ROAD, NEW DELHI**

**TENDER DOCUMENT  
PART –II  
[ SCHEDULE OF QUANTITIES ]**

ARCHITECTS:

**A.V. ARCHITECTS**

**Architects and Interior Designers**

**Address :Office and Studio: JG-III, 65-A, Ground Floor,  
Vikaspuri, New Delhi-110018,  
TeleFAX: 28547855,**

RENOVATION WORKS FOR THE OIC LTD.  
AT 103 a to 112 a sec 27 noida up

RENOVATION WORKS FOR THE OIC LTD.  
AT 103 a to 112 a sec 27 noida up



RENOVATION WORKS FOR THE OIC LTD.  
AT 103 a to 112 a Sector- 27, Noida (U.P.)

**THE ORIENTAL INSURANCE COMPANY LTD.**  
**Proposed RWH, Repair and Maintenance Works for**  
RESIDENTIAL FLATS AT- 103 A TO 112 A, SEC-27, NOIDA UP.

**SCHEDULE OF QUANTITIES**

SN	ITEM/ WORKS	Specifications	UNIT S	QTY	RATES IN FIGURES	RATES IN WORDS	AMOUNT	TOTAL
	<b>ITEM/WORKS</b>							
<b>A</b>	<b>DISMANTLING AND CIVIL WORKS</b>							
i	Removal of Super structure, sub structure, Brick works, CC lean Concrete foundation base and disposal of mulba to the nearest authorised mulba disposal site the city authority including all leads and lift.		LS	1				
ii	Excavation of the Earth and refilling	Earth work in excavation by mechanical means (Hydraulic excavator) / manual means in foundation trenches or drains for making water harvesting pit to all depth and all kinds of soils as directed including disposal of surplus soil including dressing of sides and ramming of bottoms, xcavated soil as directed to all lead and lift of 50 m.: All kinds of soil. including excavating trenches for pipes, cables, etc, and Filling available excavated earth (excluding rock) in trenches, plinth, sides of foundations etc. in layers not exceeding 20cm in depth, consolidating each deposited layer by ramming and watering,	CUM	28.61				
iii	Removal of the existing flooring disposal	Dismantling of the existing external flooring and dosposal of mulba including all lead and lifts as directed by the Architect/oic.	SQM	45.03				
	<b>TOTAL COST OF THE WORKS</b>							

RENOVATION WORKS FOR THE OIC LTD.  
AT 103 a to 112 a Sector- 27, Noida (U.P.)

SN	ITEM/ WORKS	Specifications	UNIT S	QTY	RATES IN FIGURES	RATES IN WORDS	AMOUNT	TOTAL
B	<b>FILTRATION PIT WORKS</b>							
1	Plain Cement Concrete base	Providing and laying in position cement concrete of specified grade excluding the cost of centering and shuttering - All work up to plinth level : 1:4:8 (1 Cement : 4 coarse sand : 8 graded stone aggregate 40 mm nominal size).	CUM	1.61				
2	RCC 1:2:4 for including Reinforcement , including shuttring and scaffolding	Providing and laying in position concrete specified grade for reinforced cement concrete work including the Centering and shuttering including strutting, propping etc. and removal of form for : Foundations, footings, bases of columns, etc. for finishing and reinforcement including cost of as per direction of the Engineer - in - charge.1:2:4 , Reinforced cement concrete, All works up to floor Ground level. including Reinforcement for R.C.C. work including straightening, cutting, bending, placing in position and binding all complete: Cold twisted bars.	CUM	2.00				
3	BrickWorks [ Cement Mortar 1:6] 9" THK	Brick work with F.P.S. bricks of class designation 75 in superstructure above plinth level up to floor V level in all shapes and sizes in : Cement mortar 1:4 (1 cement : 4 coarse sand).	CUM	23.00				

RENOVATION WORKS FOR THE OIC LTD.  
AT 103 a to 112 a Sector- 27, Noida (U.P.)

SN	ITEM/ WORKS	Specifications	UNIT S	QTY	RATES IN FIGURES	RATES IN WORDS	AMOUNT	TOTAL
4	Filter filling	Providing and Filling of filter including different size of filter stones 3 layers. Providing and filling in layers of the Sand filters as filter media. Sand filters to effectively remove turbidity (suspended particles like silt and clay), colour and microorganisms.the top layer comprises coarse sand followed by a 5-10 mm layer of gravel followed by another 5-25 cm layer of gravel and boulders.As per drawing. 30 , 20 , 30 mm thk layer of gravel, sand and gravel respectively and last bottom layer to be of porous bed as per drawing and instructions.	cum	4.58				

RENOVATION WORKS FOR THE OIC LTD.  
AT 103 a to 112 a Sector- 27, Noida (U.P.)

SN	ITEM/ WORKS	Specifications	UNIT S	QTY	RATES IN FIGURES	RATES IN WORDS	AMOUNT	TOTAL
5	Boring 6"	Boring of the earth to the depth till the water level of the earth water level reaches in the site area not less than 60'. The boring by mechanical and manual means. Including taking out the mud to nearest dump.	M	16.77				
6	PVC 6 " perforated pipes with all necessary fittings [6kg/cmsq]	Providing and Laying the PVC perforated pipes in the bore hole.vertically.	M	16.77				
7	PVC Pipe Connection to the existing MH and new Ft, with grating and seive jali with steps	Providing and Laying the 10" dia PVC Draingae pipe connection to the nearest MH in slope to take the / drain the Rain water inside the collector pit.	LS	1.00				
8	MORE WORKS							
II	BrickWorks [ Cement Mortar 1:6] 4 1/2" THK	Brick Work 4.5"Thick with F.P.S bricks of class designation 75 in foundation and plinth in Cement mortar 1 :6 1 cement : 6 coarse sand.	SQM	10.22				
ii	cast iron Jali	Providing and fixing in position of the CP Jali.	LS	1.00				
iii	MS Cover	Providing and fixing in position of the MS Cover 2'x 2' size including angle frame. As approved by the Engg in charge.	LS	1.00				
9	Gully trap MH Works							
i	BrickWorks [ Cement Mortar 1:6] 4 1/2" THK	Brick Work 4.5"Thick with F.P.Sbricks of class designation 75 in foundation and plinth in Cement mortar 1 6 1 cement : 6 coarse sand.	SQM	3.90				
ii	Plaster 1:4	, 1 Cement : 4 Coarse sand.	SQM	3.90				
iii	PVC Trap	Providing and fixing in position of the PVC Trap	LS	1.00				
iv	SS Sieves	Providing and fixing in position of the Sieves	Nos	2.00				
<b>C</b>	<b>FLOORING WORKS</b>							

RENOVATION WORKS FOR THE OIC LTD.  
AT 103 a to 112 a Sector- 27, Noida (U.P.)

SN	ITEM/ WORKS	Specifications	UNIT S	QTY	RATES IN FIGURES	RATES IN WORDS	AMOUNT	TOTAL
i	Terrazoo Flooring 20 mm thk in slope including grinding polishing	40 mm thick marble chips flooring rubbed and polished to granolithic finish, under layer 34 mm thick cement concrete 1:2:4 (1 cement : 2 coarse sand : 4 graded stone aggregate 12.5mm nominal size) and top layer 6mm thick with white, black, chocolate, grey, yellow or green marble chips of sizes from 1mm to 4mm nominal size laid in cement marble powder mix 3:1 (3 cement : 1 marble powder) by weight in proportion of 4:7 (4 cement marble powder mix : 7 marble chips) by volume including cement slurry etc. complete :	SQM	45.03				
	TOTAL COST OF THE WORKS							
<b>D</b>	<b>PAINT WORKS</b>							
i	Esternal paint [ snowcem]	Applying and Painting with External paint of approved brand and manufacturer and of required shade on old / new surface three or more coats to give an even shade including necessary surfacing, after thoroughly preparing the surface including curring etc. as per the manufacturer's specifications.	SQM	78.07				
	TOTAL COST OF THE WORKS							
	TOTAL ESTIMATED COST OF THE WORKS FOR ONE PAIR OF FLAT							
	<b>TOTAL COST OF THE WORKS FOR FIVE PAIRS</b>					X 5		

IF IN DOUBT, PLEASE ASK !

GENERAL NOTES:-

- G1. DO NOT SCALE THE DRAWING FOLLOW ONLY FIGURED DIMENSIONS.
- G2. ALL STRUCTURAL DRAWINGS SHOULD BE READ IN CONJUNCTION WITH RELEVANT ARCHITECTURAL DRAWINGS. ANY DISCREPANCY OR AMBIGUITY IN EITHER SHOULD BE BROUGHT TO THE NOTICE OF THE ARCHITECT
- G3. ALL DIMENSIONS AND LEVELS ARE IN FOOT.

CONCRETE:-

- C1 REINFORCED CEMENT CONCRETE SHALL BE DESIGN AS FOLLOWS:- COL.=M25, FOUNDATION=M25, PLINTH BEAM=M25, SLAB/BEMS=M25

REINFORCING STEEL:-

- R1. ALL REINFORCING STEEL WILL BE OF TESTED QUALITY CONFORMING TO IS:1786 LATEST.
- R2. REFER TO HIGH YIELD STRENGTH DEFORMED BARS WITH CHARACTERISTIC STRENGTH OF 415 N/sq. mm.
- R3. CLEAR COVER TO MAIN REINFORCEMENT SHALL BE
  - \* FOUNDATION 50 mm. ALL AROUND
  - \* COLUMNS 50 mm. ALL AROUND
  - \* BEAMS 30 mm. ALL AROUND
  - \* SLABS 20 mm. TOP & BOTTOM
  - \* WALLS 25 mm. EARTH FACE
  - \* WALLS 20 mm. INNER FACE
- R4. LAP LENGTH TO BE 50X DIA OF BAR MINIMUM.
- R5. SLAB BARS IN SHORTER DIRECTION, SHALL BE BELOW BARS FOR THE LONGER DIRECTION
- R6. IN BEAMS, FIRST STIRRUP SHALL BE AT NO MORE THAN 40 mm FROM FACE OF THE SUPPORTING MEMBER.
- R7. IN BEAMS TOP BARS ARE NOT TO BE SPLICED IN THE END QUARTERS OF THE SPAN, AND THE BOTTOM BARS ARE NOT TO BE SPLICED AT MIDDLE HALF OF THE SPAN.

CONSTRUCTION PRACTICE:-

- P1. IT IS MANDATORY TO REMOVE ALL LOOSE SOIL TILL THE FIRM SOIL IS REACHED.
- P2. BACK FILLING AROUND THE FOUNDATIONS SHALL BE CARRIED OUT USING SOIL,SAND WITHOUT GRAVEL AND
- P3. IT IS ADVASBLE TO ALLOW STANDING WATER IN THE EXCAVATION TRENCHES FOR 24 HOURS, WHEN THE SURFACE IS SANDRY, HAND RAMMING SHALL BE CARRIED OUT WITH AT LEAST 6 TO 8 PASSES
- P4. BACK FILLING OF BASEMENT WALLS SHALL BE DONE ONLY AFTER THE ROOF SLAB HAS BEEN DEROPPED.
- P5. IN NORMAL CIRCUMSTANCES AND WHERE ORDINARY PORTLAND CEMENT IS USED, FORMS MAY GENERALLY BE REMOVED AFTER THE EXPIRY OF THE FOLLOWING PERIODS
  - \* WALLS, COLUMNS AND VERTICAL 36 TO 48 HOURS
  - \* SLABS (PROPS LEFT UNDER) 3 DAYS
  - \* BEAM SOFFITS (PROPS LEFT UNDER) 7 DAYS
  - \* REMOVAL OF PROPS UNDER SLABS 7 DAYS
  - SPANNING UP TO 3000 14 DAYS
  - SPANNING OVER 3000 14 DAYS
  - \* REMOVAL OF PROPS UNDER BEAMS 14 DAYS
  - SPANNING UP TO 4500 14 DAYS
  - SPANNING OVER 4500 21 DAYS
- P6. WHERE POSSIBLE, THE FORMWORK SHALL BE LEFT LONGER, AS IT WOULD ASSIST CURING.

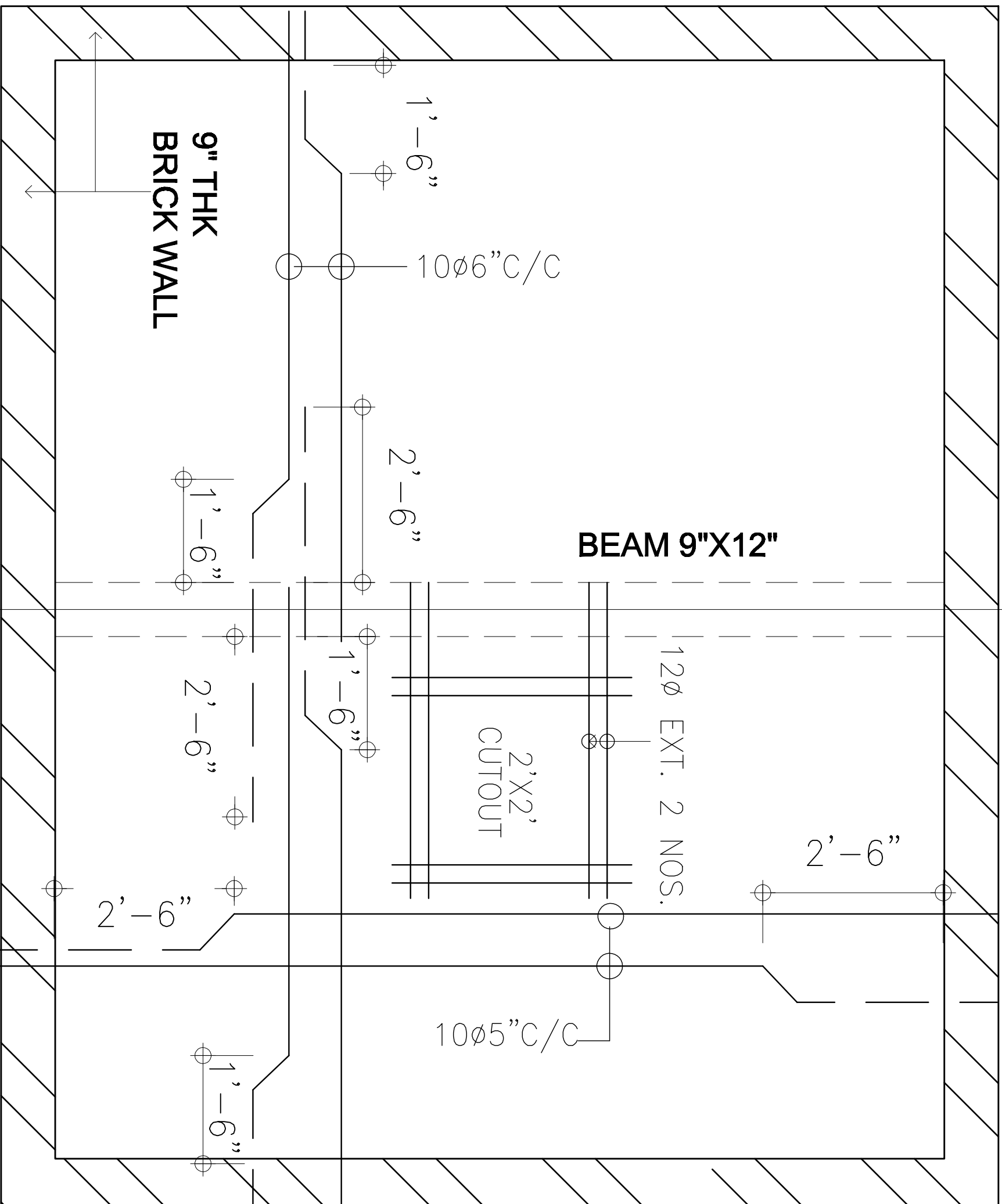

REINFORCEMENT DETAILS OF ROOF SLAB OF RAIN WATER HARVESTING PIT

BEAM (9"X12")

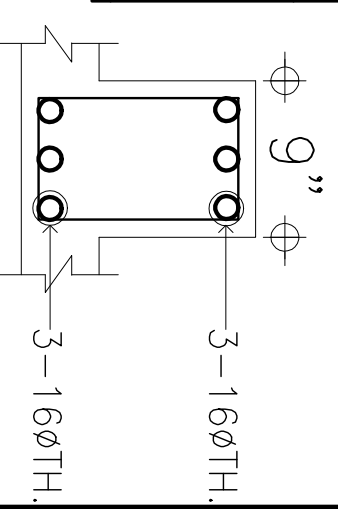

Firm Name and Address  
**A.V. architects**  
ARCHITECTS, INTERIOR DESIGNERS, AND URBAN DESIGNERS  
JG-III, 65-A, VIKASPURI,  
NEW DELHI-110018.

Project Name and Address  
Proposed ID works of Residence of  
**O.I.C.**  
Flats at NOIDA  
U.P.

Project  
RCC. RWH

Date: 05/09/12

Scale : FT

Sheet  
DRG.-3/3

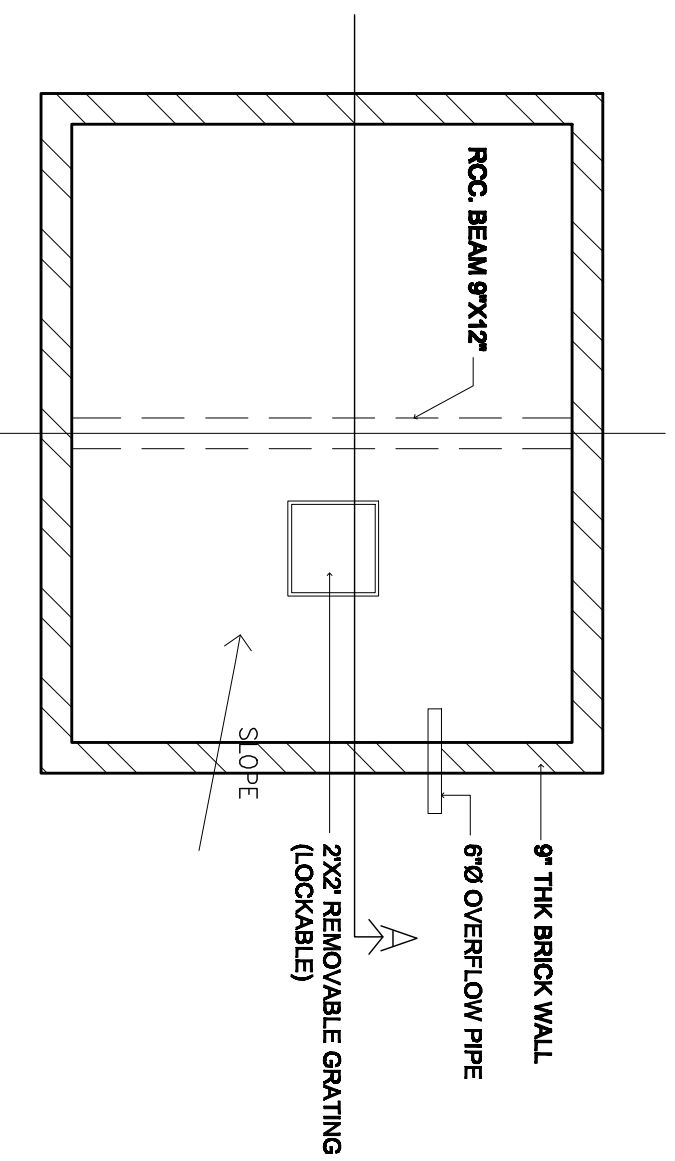

**RAIN WATER HARVESTING PIT - PLAN**

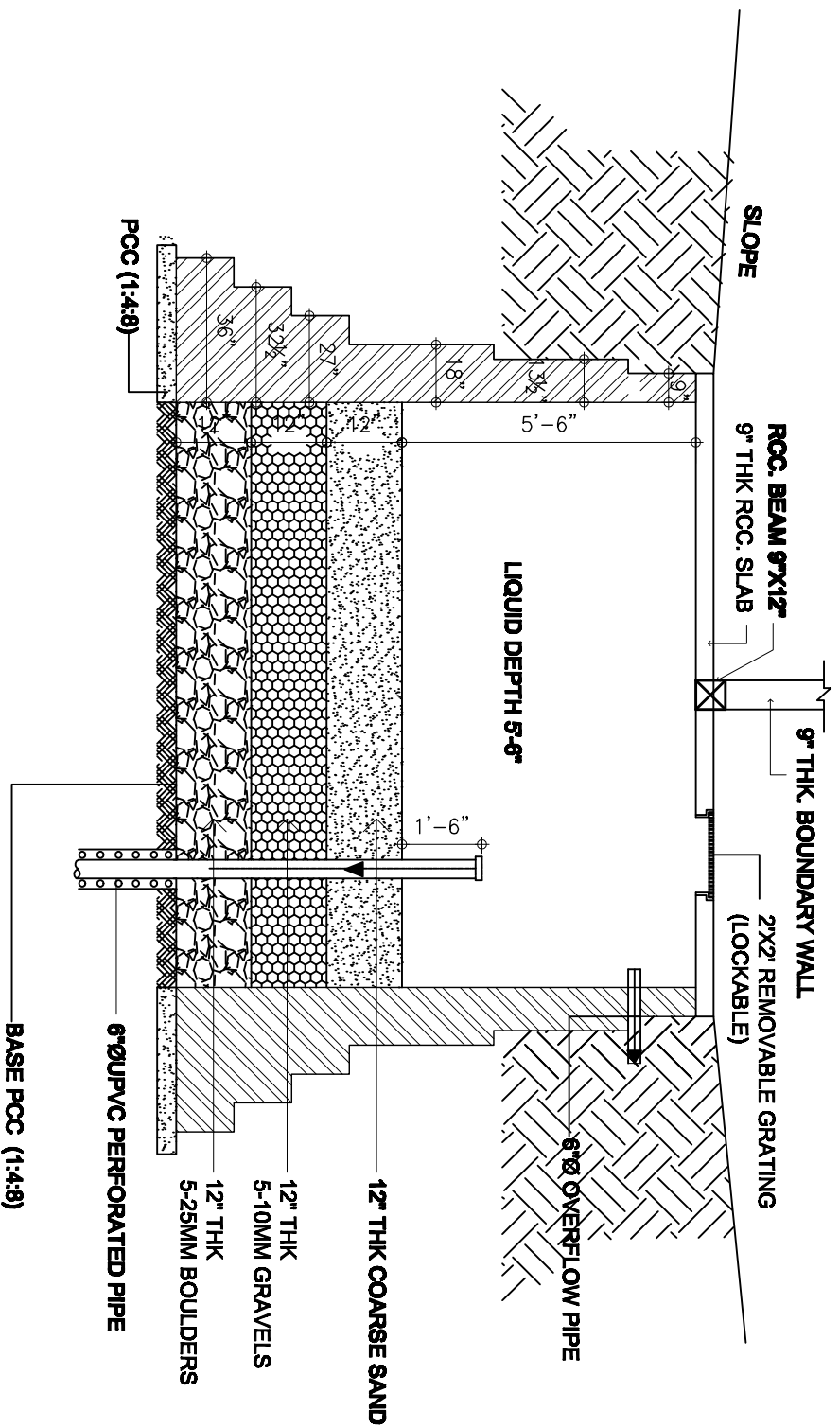

**RAIN WATER HARVESTING PIT. SECTION**

**General Notes**

C All rights reserved.  
 This drawing is the property of M/s A.V. Architects & may not be copied/ reproduced/ transmitted by any means in whole or part without the permission of the owners.

All the dimensions are to be read not to be measured.

No.	Revision/Issue	Date

Firm Name and Address  
**A.V. architects**  
 ARCHITECTS, INTERIOR DESIGNERS, AND URBAN DESIGNERS  
 JG-III, 65-A, VIKASPURI,  
 NEW DELHI=110018.

Project Name and Address  
**Proposed ID works of Residence of O.I.C. Flats at NOIDA U.P.**

Project <b>W/H PIT</b>	Sheet
Date: <b>05/09/12</b>	
Scale : FIT	<b>DRG.-2/2</b>

TOTAL OF PITTS =5 NOS.  
 DETAIL DRAWING - PIT  
 PAIR OF FLATS

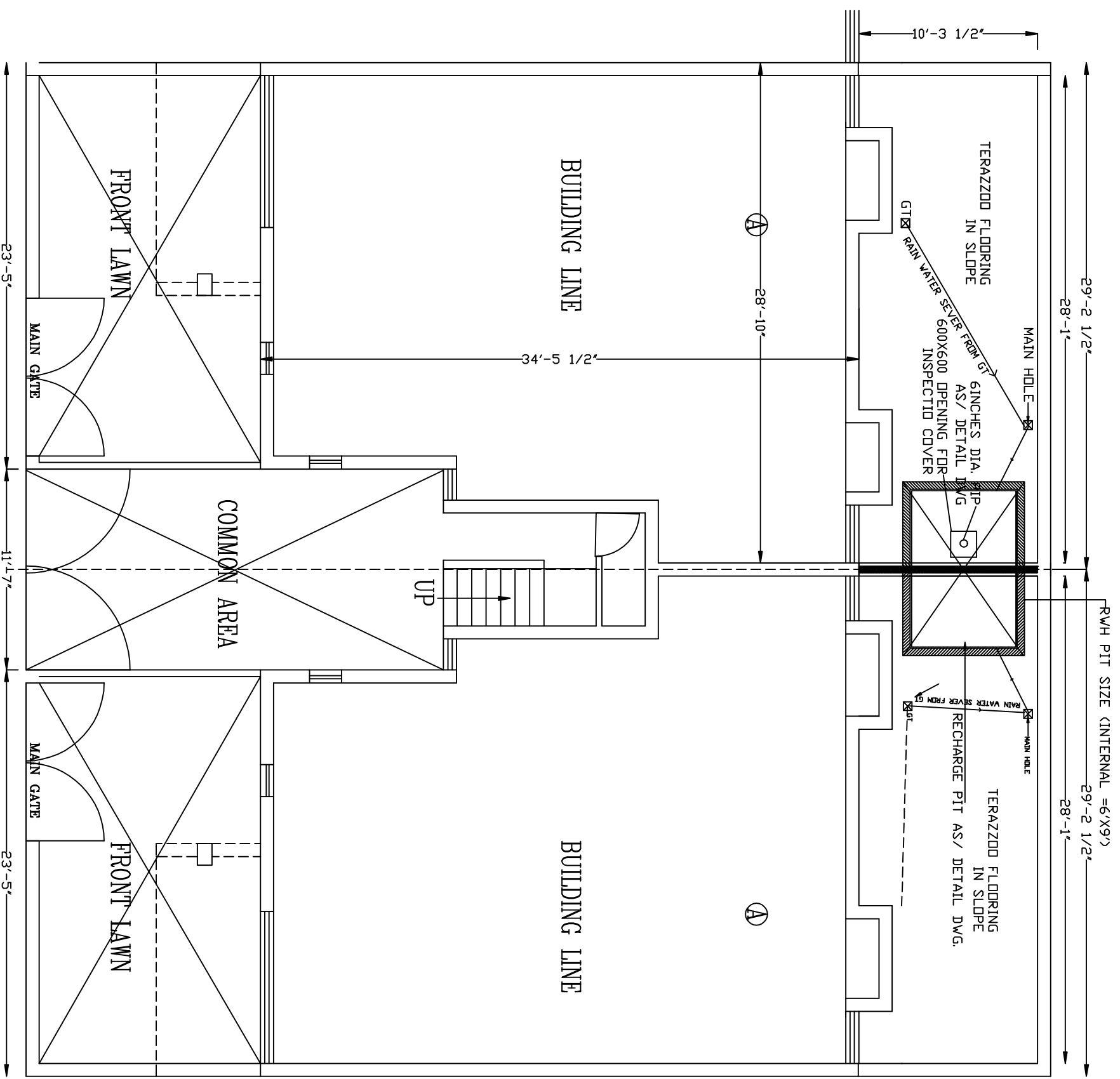

**General Notes**

C All rights reserved.  
 This drawing is the property of M/s A.V. Architects & may not be copied/ reproduced/ transmitted by any means in whole or part without the permission of the owners.

All the dimensions are to be read not to be measured.

No.	Revision/Issue	Date

Firm Name and Address  
**A.V. architects**  
 ARCHITECTS, INTERIOR DESIGNERS, AND URBAN DESIGNERS  
 JG-III, 65-A, VIKASPURI,  
 NEW DELHI=110018.

Project Name and Address  
**Proposed ID works of Residence of O.I.C. Flats at NOIDA U.P.**

Project **LAYOUT** Sheet  
 Date: **05/09/12**  
 Scale : FIT **DRG.-1/3**

TOTAL OF PITTS =5 NOS.  
 DETAIL DRAWING - PIT  
 PAIR OF FLATS